

Product data sheet

Characteristics

H361NRB

Safety switch, heavy duty, fusible, 30A, 3 poles, 20 hp, 20 hp, 600 VAC/DC, NEMA 3R, bolt-on hub, neutral

Product availability : Stock - Normally stocked in distribution facility



Price* : 986.00 USD



Main

Product	Single Throw Safety Switch
Current Rating	30 A
Certifications	UL listed file E2875
Enclosure Rating	NEMA 3R galvanized steel
Factory Installed Neutral	Neutral (factory installed)
Disconnect Type	Fusible disconnect
Short Circuit Current Rating	10 kA H or K 200 kA R, J or L
Mounting Type	Surface
Number of Poles	3
Electrical Connection	Lugs
Duty Rating	Heavy duty
Voltage Rating	600 V AC/DC
Wire Size	AWG 12...AWG 6 aluminium AWG 14...AWG 6 copper

Complementary

Maximum Horse Power Rating	5 hp 480 V AC 50...60 Hz 3 phase NEC 240.6 15 hp 480 V AC 50...60 Hz 3 phase NEC 430.52 7.5 hp 600 V AC 50...60 Hz 3 phase NEC 240.6 20 hp 600 V AC 50...60 Hz 3 phase NEC 430.52 15 hp 600 V DC
Maximum Height	14.88 in (377.95 mm)
Depth	4.86 in (123.44 mm)
Width	7.55 in (191.77 mm)

* Price is "List Price" and may be subject to a trade discount – check with your local distributor or retailer for actual price.

Tightening torque	45 lbf.in (5.08 N.m) 0.02 in ² (13.3 mm ²) AWG 6) 40 lbf.in (4.52 N.m) 0.01 in ² (8.367 mm ²) AWG 8) 35 lbf.in (3.95 N.m) 0.00...0.01 in ² (2.06...5.261 mm ²) AWG 14...AWG 10)
-------------------	--

Ordering and shipping details

Category	00009 - H&HU SW,2&3P,N3R,30-200A
Discount Schedule	DE1
GTIN	00785901122487
Nbr. of units in pkg.	1
Package weight(Lbs)	8.77 lb(US) (3.98 kg)
Returnability	Yes
Country of origin	US

Packing Units

Unit Type of Package 1	PCE
Package 1 Height	5.20 in (13.208 cm)
Package 1 width	7.70 in (19.558 cm)
Package 1 Length	16.20 in (41.148 cm)
Unit Type of Package 2	PAL
Number of Units in Package 2	120
Package 2 Weight	1086.00 lb(US) (492.601 kg)
Package 2 Height	45.50 in (115.57 cm)
Package 2 width	40.00 in (101.6 cm)
Package 2 Length	48.00 in (121.92 cm)

Offer Sustainability

Sustainable offer status	Green Premium product
RECh free of SVHC	Yes
EU RoHS Directive	Compliant EU RoHS Declaration
Mercury free	Yes
RoHS exemption information	Yes
China RoHS Regulation	China RoHS declaration Product out of China RoHS scope. Substance declaration for your information.
Environmental Disclosure	Product Environmental Profile
PVC free	Yes

Contractual warranty

Warranty	18 months
----------	-----------

Approximate Dimensions

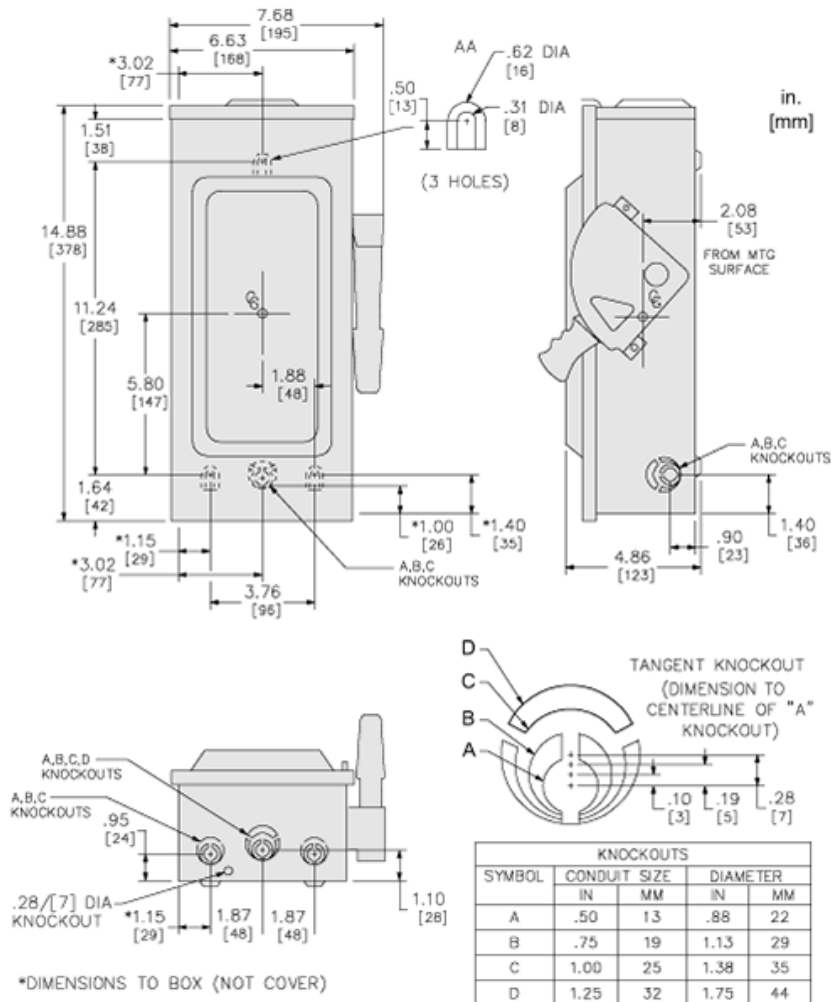

Connections and Wiring Diagrams

CATALOG NUMBER	VOLTAGE RATINGS	AMPERAGE RATINGS	WIRING DIAG
H221NRB	240VAC,250VDC	30	A
H321NRB	240VAC,250VDC	30	B
H361NRB	600VAC,600VDC	30	B
H361RB	600VAC,600VDC	30	C
HU361RB	600VAC,600VDC	30	D
HU361RBEI	600VAC,600VDC	30	D
HU361NRB	600VAC,600VDC	30	E

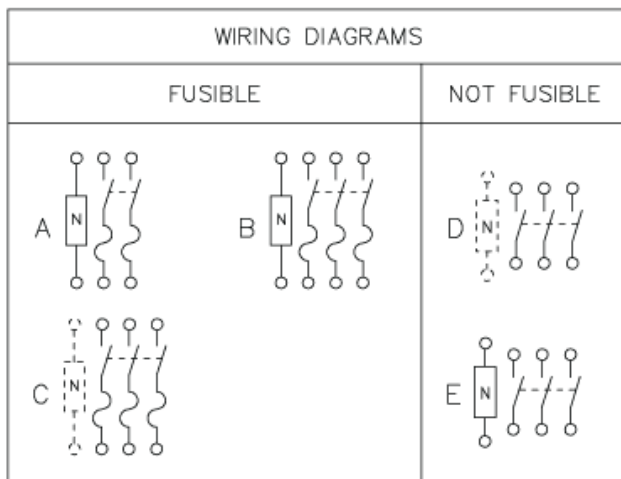

TERMINAL LUGS			
AMPERES	MAX WIRE	MIN WIRE	TYPE
30	#6 AWG	#14 AWG	AL OR CU